

<b>CE</b>	<b>Instruction Manual / 使用手冊</b>	F - □□
	<b>KTF Thermal Mass Flow Sensor</b> Series 熱質式流量感測器	

### ◆ Guiding of model / 型號索引

#### KTF - 050 - A - N2

1          2          3          4

##### 1 : Series / 系列

「KTF」 = Paddle Wheel Flow Sensor

##### 2 : Flow range / 流量

「050」 = 「50LPM (nor.) , 1/4"」

「080」 = 「80LPM (nor.) , 1/4"」

「100」 = 「100LPM (nor.) , 1/4"」

「200」 = 「200LPM (nor.) , 1/2"」

「300」 = 「300LPM (nor.) , 1/2"」

「400」 = 「400LPM (nor.) , 3/4"」

「500」 = 「500LPM (nor.) , 3/4"」

##### 3 : Transmitter / 傳送方式

「A」 = 4 ~ 20mA + Pulse output

「V」 = 0 ~ 5 V + Pulse output

##### 4 : Gases / 量測氣體

「N2」 = N2

「O2」 = O2

「Da」 = Dry air

### ◆ Specification / 規格

Specification	規格	Description
Gases	量測流體	N2,O2 or Dry air
Measuring range	量測範圍	Min. 0 ~ 50 L/min (nor.) ; Max. 0 ~ 500 L/min.
Accuracy	量測精度	± 2.0% of F.S. @ 25°C
Low cut	最小流速	< 2% of F.S.
Operating press.	工作壓力	- 0.07 ~ 0.98Mpa
Response time	反應時間	3 sec max.
Operating voltage	工作電壓	12 VDC ± 10%
Ripple of power	電源漣波	10% peak to peak
Current consumption	消耗電流	250mA max.
Transmitter	傳送方式	Linear output (4 ~ 20mA) or (0 ~ 5 V)
Resistance of output	輸出阻抗	50Ω max.
Material of body	本體材質	SUS 316
Material of housing	外殼材質	ABS
Operating circumstance	工作環境	5°C ~ + 50°C ; 35% ~ 85% RH
Protection class	保護等級	IP- 65
Approval	認證	CE

### ◆ Dimension / 外形圖

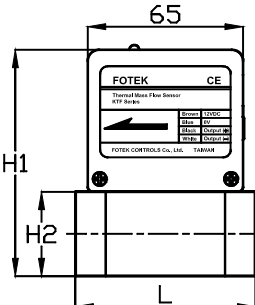
	Measuring range (LPM)	H1 (mm)	H2 (mm)	L (mm)
	50 / 80 / 100	89.5	25	76
200	96.5	32	76	
300	96.5	32	112	
400	102.5	38	112	
500	102.5	38	112	

## ◆ Wiring diagram / 接線圖

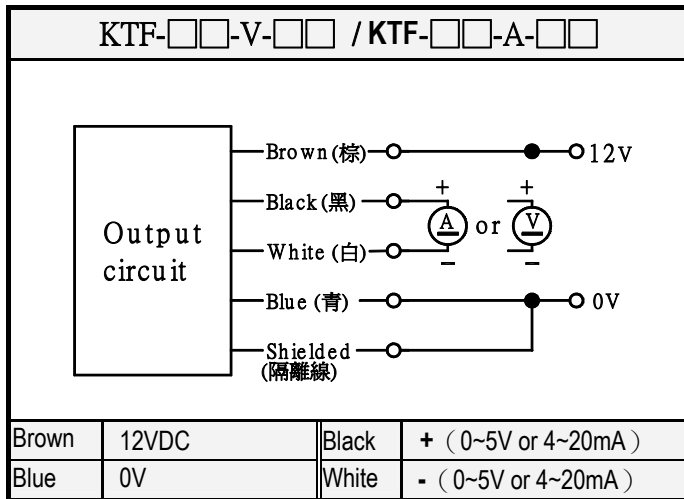

## ◆ Connector of pipe / 接頭

TMF-□□□-□-□	Flow range	Connector
050	50LPM	1/4" RC
080	80LPM	1/4" RC
100	100LPM	1/4" RC
200	200LPM	1/2" RC
300	300LPM	1/2" RC
400	400LPM	3/4" RC
500	500LPM	3/4" RC

## ◆ Notice of Installation / 安裝注意事項

- 1 > Please clean the pipe line before installing the measuring unit.  
安裝流量感測器前請先清潔管線。
- 2 > Please set enough length of straight pipe to avoid the vortex might be existed.  
(The minimum straight upstream must be over 10 x DN and downstream must be observed over 5 x DN)  
安裝流量感測器時請在流量感測器前後保留適當長度的直管以防止產生窩流。
- 3 > Please select the suitable piping connector as specification.  
請依流量感測器管牙規格選用適當的接管配件
- 4 > Please install the measuring unit according the direction of arrow indicated on the body of the measuring unit.  
請依流量感測器標示方向安裝
- 5 > Please offer correct operating power supply : 250mA / 12VDC ±10%  
請提供正確的工作電源：250mA / 12VDC ±10%
- 6 > Please warm up the measuring unit at least 30 minutes to get the stable output signal.  
本流量感測器須熱機 30 分鐘以上才會穩定。

## ◆ Range of transmitter / 傳送器轉換範圍

KTF series	050	080	100	200	300	400	500
Range (LPM)	0~50	0~ 80	0 ~ 100	0 ~ 200	0 ~ 300	0~400	0~500
Remarks	2 > Range of transmitter : It is transmitted to 「4.0 ~ 20.0 mA」 or 「0.0 ~ 5.0 V」 傳送範圍：依傳送範圍轉換成「4.0 ~ 20.0 mA」或「0.0 ~ 5.0 V」 2 > It is accepted to modify the range of transmitter on customer's demand. 可依客戶需求修改傳送器轉換範圍。						

陽明電機股份有限公司  
FOTEK CONTROLS CO.,LTD.